

Date of Issuance: 07/02/2024	Effective Date: 08/28/2023
Owner: Town of Pendelton	Owner's Contract No.: #219091-21-049E
Contractor: CIR Electrical	Contractor's Project No.:
Engineer: Nussbaumer & Clarke, Inc	Engineer's Project No.: 22J1-0123
Project: Town of Pendelton Community Center	Contract Name: Electrical Contract

The Contract is modified as follows upon execution of this Change Order:

Description:

This Change Order is in reference to:

- Providing a Pull Box for Conduit from Town Hall to Community Center

Attachments: CIR-COR #12 - Quazite Box for Town Hall Data

CHANGE IN CONTRACT PRICE	CHANGE IN CONTRACT TIMES <i>[note changes in Milestones if applicable]</i>
Original Contract Price: \$ 398,150.00	Original Contract Times: Substantial Completion: <u>N/A</u> Ready for Final Payment: <u>N/A</u> days or dates
[Increase] [Decrease] from previously approved Change Orders No. <u>EC-1</u> to No. <u>EC-10</u> : \$ <u>77,294.37</u>	[Increase] [Decrease] from previously approved Change Orders No. <u>N/A</u> to No. <u>N/A</u> : Substantial Completion: _____ Ready for Final Payment: _____ days
Contract Price prior to this Change Order: \$475,444.37	Contract Times prior to this Change Order: Substantial Completion: <u>N/A</u> Ready for Final Payment: <u>N/A</u> days or dates
Increase of this Change Order: \$ <u>689.43</u>	[Increase] [Decrease] of this Change Order: Substantial Completion: <u>N/A</u> Ready for Final Payment: <u>N/A</u> days or dates
Contract Price incorporating this Change Order: \$ <u>475,444.37 – No Change-Using Allowance</u>	Contract Times with all approved Change Orders: Substantial Completion: <u>N/A</u> Ready for Final Payment: <u>N/A</u> days or dates

RECOMMENDED:

ACCEPTED:

ACCEPTED:

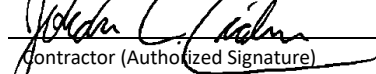
By: _____ Engineer (if required)	By: _____ Owner (Authorized Signature)	By:  Contractor (Authorized Signature)
Title: <u>07/02/2024</u>	Title: _____	Title: <u>Jordan Cialone, CIR Project Manager</u>
Date: <u>Associate – Construction Services</u>	Date: _____	Date: <u>07/02/2024</u>



2517 Long Rd.
Grand Island, NY 14072

CHANGE ORDER REQUEST RECAP

Job Name: Pendleton Community Center

Date: 6/26/2024

Contract No.: 21-049E

Change Order Request No.: 12

CIR Job No.: 2302023

Description:

CIR to provide (1) Quazite PG1324BA18 hand hole with cover to the Town of Pendleton for installation by Town of Pendleton personnel. Quazite box to be used as a pull point for the 3" communications conduits being installed by the Town of Pendleton between the community center and the town hall buildings.

Material Description	Material	Labor Description	Hours	Rate	Labor Cost	
Attached Quote #0245069444	\$ -	Foreman ST	-	\$ -	\$ -	
(1) PG1324BA18 13X24X18 Box	\$ 265.95	Apprentice ST	-	\$ -	\$ -	
(1) PG1324CA0042 Cover Marked "Telephone"	\$ 322.14					
Material Cost Subtotal:	\$ 588.09					
Job Expenses:		Supervision (0%)	0.000	\$ 92.00	\$ -	
Document Control	\$ -	Tool Usage (4% of Labor)			\$ -	
Travel Time Costs	\$ -	Total Labor Costs:			\$ -	
Telephone	\$ -	SUBTOTAL(L+M+JE)			\$ 588.09	
Transportation	\$ -	Research & Layout		0%	\$ -	
Storage / Warehouse	\$ -	Material Handling		0%	\$ -	
Safety (3% of Labor Cost)	\$ -	Clean Up Costs:		0%	\$ -	
Inspections & Permits	\$ -					
Record Drawings	\$ -					
Fuel Surcharges (4% of Material Cost)	\$ -	SUBTOTAL:			\$ 588.09	
		Overhead		10%	\$ 58.81	
Total Job Expenses	\$ -	Profit		5%	\$ 32.34	
Qualifications & Clarifications: 1.) Sales Tax is NOT included 2.) Straight Time only-NO overtime included 3.) No cutting and patching included 4.) Schedule Impact		Subcontractor Amount			\$ -	
		Subcontractor Mark-up		15%	\$ -	
		TOTAL:				\$ 679.24
		Tax on Total		-		\$ -
		Bond Cost		2%		\$ 10.19
		Change Order Request Total			\$ 689.43	

We reserve the right to correct any and all errors and omissions



425 CAYUGA ROAD STE 100
 CHEEKTOWAGA NY 14225
 Phone: 716-565-5911
 Fax: 716-565-5999

To: CIR ELECTRIC
 2517 LONG ROAD
 GRAND ISLAND NY 14072
 Attn: Jordan Cialone
 Phone: 716-362-5000
 Fax: 716-362-5010
 Email: thomas.lisacchi@graybar.com

Date: 12/28/2023
Proj Name: WILSON CSD ENCLOSURE
GB Quote #: 0245069444
 Release Nbr:
 Purchase Order Nbr:
 Additional Ref#
 Valid From: 12/28/2023
 Valid To: 01/27/2024
 Contact: Tom LiSacchi
 Email: thomas.lisacchi@graybar.com

Proposal

We Appreciate Your Request and Take Pleasure in Responding As Follows

Item	Item/Type	Quantity	Supplier	Catalog Nbr	Description	Price	Unit	Ext.Price
100		2 EA	HUBBELL INC	PG1324BA18	STK BOX OB 13X24X18	\$265.95	1	\$531.90
GB Part #: 89005017 UPC #: 66203710039								
Item Note: In Stock.								
200		2 EA	HUBBELL INC	PG1324CA0043	{TELEPHONE}	\$322.14	1	\$644.28
Item Note: No Stock, 1-1.5 Month Lead.								

Total in USD (Tax not included): \$1,176.18

This equipment and associated installation charges may be financed for a low monthly payment through Graybar Financial Services (subject to credit approval). For more information call 1-800-241-7408 to speak with a leasing specialist.

To learn more about Graybar, visit our website at www.graybar.com 24-Hour Emergency Phone#: 1-800-GRAYBAR

Subject to the standard terms and conditions set forth in this document. Unless otherwise noted, freight terms are F.O.B. shipping point prepaid and bill. Unless noted the estimated ship date will be determined at the time of order placement.

To: CIR ELECTRIC
2517 LONG ROAD
GRAND ISLAND NY 14072
Attn: Jordan Cialone

Date: 12/28/2023
Proj Name: WILSON CSD ENCLOSURE
GB Quote #: 0245069444

Proposal

We Appreciate Your Request and Take Pleasure in Responding As Follows

GRAYBAR ELECTRIC COMPANY, INC. TERMS AND CONDITIONS OF SALE

1. ACCEPTANCE OF ORDER; TERMINATION - Acceptance of any order is subject to credit approval and acceptance of order by Graybar Electric Company, Inc. ("Graybar") and, when applicable, Graybar's suppliers. If credit of the buyer of the goods or services ("Buyer") becomes unsatisfactory to Graybar, Graybar reserves the right to terminate upon notice to Buyer and without liability of Graybar.
2. GENERAL PROVISIONS - All typographical or clerical errors made by Graybar in any quotation, acknowledgment or publication are subject to correction. This agreement shall be governed by the laws of the State of Missouri applicable to contracts to be formed and fully performed within the State of Missouri, without giving effect to the choice of conflicts of law provisions thereof. All suits arising from or concerning this agreement shall be filed in the Circuit Court of St. Louis County, Missouri, or the United States District Court for the Eastern District of Missouri, and no other place unless otherwise determined in Graybar's sole discretion. Buyer hereby irrevocably consents to the jurisdiction of such court or courts and agrees to appear in any such action upon written notice thereof.
3. MODIFICATION OF TERMS AND CONDITIONS - These terms and conditions, and any associated statement of work, supersede all other communications, negotiations, and prior oral or written statements regarding the subject matter of these terms and conditions. No change, modification, rescission, discharge, abandonment, or waiver of these terms and conditions shall be binding upon Graybar unless made in writing and signed on its behalf by a duly authorized representative of Graybar. No conditions, usage of trade, course of dealing or performance, understanding or agreement, purporting to modify, vary, explain, or supplement these terms and conditions shall be binding unless hereafter made in writing and signed by the party to be bound. Any proposed modifications or additional terms are specifically rejected and deemed a material alteration hereof. If this document shall be deemed an acceptance of a prior offer by Buyer, such acceptance is expressly conditional upon Buyer's assent to any additional or different terms set forth herein.
4. PRICES AND SHIPMENTS - Prices for goods shall be those in effect at time of shipment, which shall be made F.O.B. shipping point, prepaid and bill. Delivery dates are subject to change and prices may increase between the time that a quote is given or an order is placed and the time of shipment. Buyer acknowledges and accepts this risk and agrees to pay the price of goods that is in effect at time of shipment in order to account for any price increases between the date of quote or order and the date of shipment. Unless otherwise indicated in the applicable quotation or statement of work, prices for services shall be those in effect at the time of completion. The contract price for goods and/or services shall be increased by the amount of any applicable tariff, excise, fee, assessment, levy, charge or duty of any kind whatsoever, imposed, assessed or collected by any governmental body, whether or not reflected in the costs charged to Graybar, and Graybar may increase its cost for goods and/or services appropriately to take into account such increases in Graybar's costs.
5. REELS - When Graybar ships returnable reels, a reel deposit may be included in the invoice. The Buyer should contact the nearest Graybar service location to return reels.
6. RETURN OF GOODS - Credit may be allowed for goods returned with prior approval. A deduction may be made from credits issued to cover cost of handling and restocking fees charged by the manufacturers of the goods. Returns will not be accepted for services or any material which has been modified at the request of or by Buyer. In addition, no custom orders may be returned, and goods must be in original packaging.
7. TAXES - Prices shown do not include sales or other taxes imposed on the sale of goods or services. Taxes now or hereafter imposed upon sales, shipments or services will be added to the purchase price. Buyer agrees to reimburse Graybar for any such tax or provide Graybar with acceptable tax exemption certificate.
8. PAYMENT TERMS - Payment terms shall be as stated on Graybar's invoice or as otherwise mutually agreed. As a condition of the sales agreement, a monthly service charge of the lesser of one and one-half percent (1.5%) or the maximum permitted by law may be added to all accounts not paid by net due date. Visa, MasterCard, American Express, and Discover credit cards are accepted at point of purchase only.
9. DELAY IN DELIVERY - Graybar is not to be accountable for delays in delivery occasioned by acts of God, failure of its suppliers to ship or deliver on time, or other circumstances beyond Graybar's reasonable control, including, but not limited to, sourcing, shipment or delivery issues caused by, related to, or resulting from COVID-19 or other similar national or global health situations. Factory shipment or delivery dates are the best estimates of our suppliers, and in no case shall Graybar be liable for any consequential or special damages arising from any delay in shipment or delivery.
10. CANCELLATION; CHANGES FOR SERVICES - Buyer may cancel or make changes to a statement of work up to five (5) business days prior to commencement of the work. All changes and cancellations after such date are subject to Graybar's prior written approval in Graybar's sole and absolute discretion. Buyer shall pay to Graybar amounts necessary to cover cancellation, restocking fees and other charges applicable to the cancelled goods or services including those incurred or committed to by Graybar.
11. SOFTWARE AND FIRMWARE - Graybar or the applicable third-party owner will retain all rights of ownership and title in its own intellectual property, including all copyrights relating to firmware and software and all copies of such firmware and software. Buyer acknowledges that all software is governed by terms expressly granted in the applicable agreement provided by such third-party owner or licensor and agrees to comply with any such terms and conditions in connection with the use or resale of such software. Graybar provides the software "AS IS" WITH ALL FAULTS, and the only warranties provided for software, if any, are provided by the third-party owner or licensor of such software. Although Graybar may collect fees relating to such software, the end user's agreement is with the third-party owner or licensor, and Buyer holds Graybar harmless from and against any claims arising out of or related to such firmware or software.
12. LIMITED WARRANTIES - Graybar warrants that all goods sold are free of any security interest and will make available to Buyer all transferable warranties (including without limitation warranties with respect to intellectual property infringement) made to Graybar by the manufacturer of the goods. Buyer acknowledges that the performance of any service which alters the manufacturer provided goods, as indicated in the statement of work, may void the manufacturer's warranty. Graybar shall use the same care and skill a similarly situated provider of like services would exercise following commonly accepted industry practices in the performance of its duties under this agreement. GRAYBAR MAKES NO OTHER EXPRESS OR IMPLIED WARRANTIES, AND SPECIFICALLY DISCLAIMS ALL IMPLIED WARRANTIES INCLUDING BUT NOT LIMITED TO THE IMPLIED WARRANTIES OF MERCHANTABILITY AND FITNESS FOR PURPOSE, UNLESS OTHERWISE AGREED IN WRITING BY AN AUTHORIZED REPRESENTATIVE OF GRAYBAR. PRODUCTS SOLD HEREUNDER ARE NOT INTENDED FOR USE IN OR IN CONNECTION WITH (1) ANY SAFETY APPLICATION OR THE CONTAINMENT AREA OF A NUCLEAR FACILITY, OR (2) IN A HEALTHCARE APPLICATION, WHERE THE GOODS HAVE POTENTIAL FOR DIRECT PATIENT CONTACT OR WHERE A SIX (6) FOOT CLEARANCE FROM A PATIENT CANNOT BE MAINTAINED AT ALL TIMES.
13. LIMITATION OF LIABILITY - Buyer's remedies under this agreement are subject to any limitations contained in manufacturer's terms and conditions to Graybar, a copy of which will be furnished upon written request. Furthermore, Graybar's liability shall be limited to either repair or replacement of the goods, re-performance of the services, or refund of the purchase price, all at Graybar's option, and IN NO CASE SHALL GRAYBAR BE LIABLE FOR INCIDENTAL, SPECIAL, OR CONSEQUENTIAL DAMAGES. In addition, claims for shortages, other than loss in transit, must be made in writing not more than five (5) days after receipt of shipment. Unless otherwise agreed in the applicable statement of work, acceptance of services will occur not more than five (5) days after completion of performance.
14. WAIVER - The failure of Graybar to insist upon the performance of any of the terms or conditions of this agreement or to exercise any right hereunder shall not be deemed to be a waiver of such terms, conditions, or rights in the future, nor shall it be deemed to be a waiver of any other term, condition, or right under this agreement.
15. ASSIGNMENT - Buyer shall not assign its rights or delegate its duties hereunder or any interest herein without the prior written consent of Graybar, and any such assignment, without such consent, shall be void.
16. CERTIFICATION - Graybar hereby certifies that these goods were produced in compliance with all applicable requirements of Sections 6, 7, and 12 of the Fair Labor Standards Act, as amended, and of regulations and orders of the United States Department of Labor issued under Section 14 thereof. This agreement is subject to Executive Order 11246, as amended, the Rehabilitation Act of 1973, as amended, the Vietnam Veterans Readjustment Assistance Act of 1974, as amended, E.O. 13496, 29 CFR Part 471, Appendix A to Subpart A, and the corresponding regulations, to the extent required by law. 41 CFR 60-1.4, 60-741.5, and 60-250.5 are incorporated herein by reference, to the extent legally required.
17. FOREIGN CORRUPT PRACTICES ACT - Buyer shall comply with applicable laws and regulations relating to anti-corruption, including, without limitation, (i) the United States Foreign Corrupt Practices Act (FCPA) (15 U.S.C. §§ 78dd-1, et. seq.) irrespective of the place of performance, and (ii) laws and regulations implementing the Organization for Economic Cooperation and Development's Convention on Combating Bribery of Foreign Public Officials in International Business Transactions, the U.N. Convention Against Corruption, and the Inter-American Convention Against Corruption in Buyer's country or any country where performance of this agreement or delivery of goods will occur.
18. EXPORTING - Buyer acknowledges that this order and the performance thereof are subject to compliance with any and all applicable United States laws, regulations, or orders. Buyer agrees to comply with all such laws, regulations, and orders, including, if applicable, all requirements of the International Traffic in Arms Regulations and/or the Export Administration Act, as may be amended. Buyer further agrees that if the export laws are applicable, it will not disclose or re-export any technical data received under this order to any countries for which the United States government requires an export license or other supporting documentation at the time of export or transfer, unless Buyer has obtained prior written authorization from the United States Office of Export Control or other authority responsible for such matters.

Signed: _____

This equipment and associated installation charges may be financed for a low monthly payment through Graybar Financial Services (subject to credit approval). For more information call 1-800-241-7408 to speak with a leasing specialist.

To learn more about Graybar, visit our website at www.graybar.com

24-Hour Emergency Phone#: 1-800-GRAYBAR

Subject to the standard terms and conditions set forth in this document. Unless otherwise noted, freight terms are F.O.B. shipping point prepaid and bill.

Unless noted the estimated ship date will be determined at the time of order placement.



Box, Polymer Concrete, 13"x24"x18"

By QUAZITE
Catalog # [PG1324BA18](#)

Quazite® ANSI/SCTE 77 certified enclosure boxes, feature a high quality polymer concrete construction in a multitude of sizes and depths allowing customization for any application.



*Representative Image

Features

- Stronger and lighter weight than regular concrete
- Cost effective
- Durable and long lasting
- Fire and chemical resistant
- Standard sizes are UL certified
- ANSI/SCTE77 certified
- Multiple styles and sizes available

General

Catalog Number	PG1324BA18
EU RoHS Indicator	No
Insulated?	No
Load Rating (ANSI Tier)	T22
Material	Polymer Concrete
Type	Below Ground Boxes
UPC	662037100391

Dimensions

Dimensions	24 in x 13 in x 18 in
Height	18 in
Length	24 in
Weight	76.65 lb
Width	13 in

Product Assets

- [Catalogs - Underground Enclosures](#)
- [Sales Drawings - Quazite Box 13 X 24 X 18](#)
- [Video - PenCell® Enclosures](#)
- [Video - Hubbell Power Systems How to Install Small Enclosures](#)
- [Video - Hubbell Power Systems How to Install Large Enclosures](#)



A proud member of the Hubbell Family.

©2024 Hubbell Incorporated. All rights reserved.
QUAZ-PG1324BA18-SPEC-EN | REV 6/2024

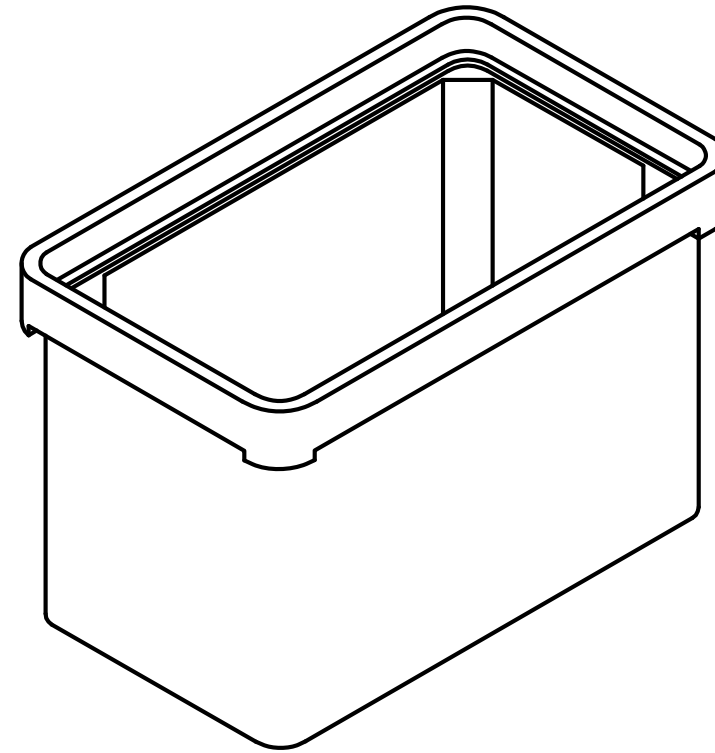
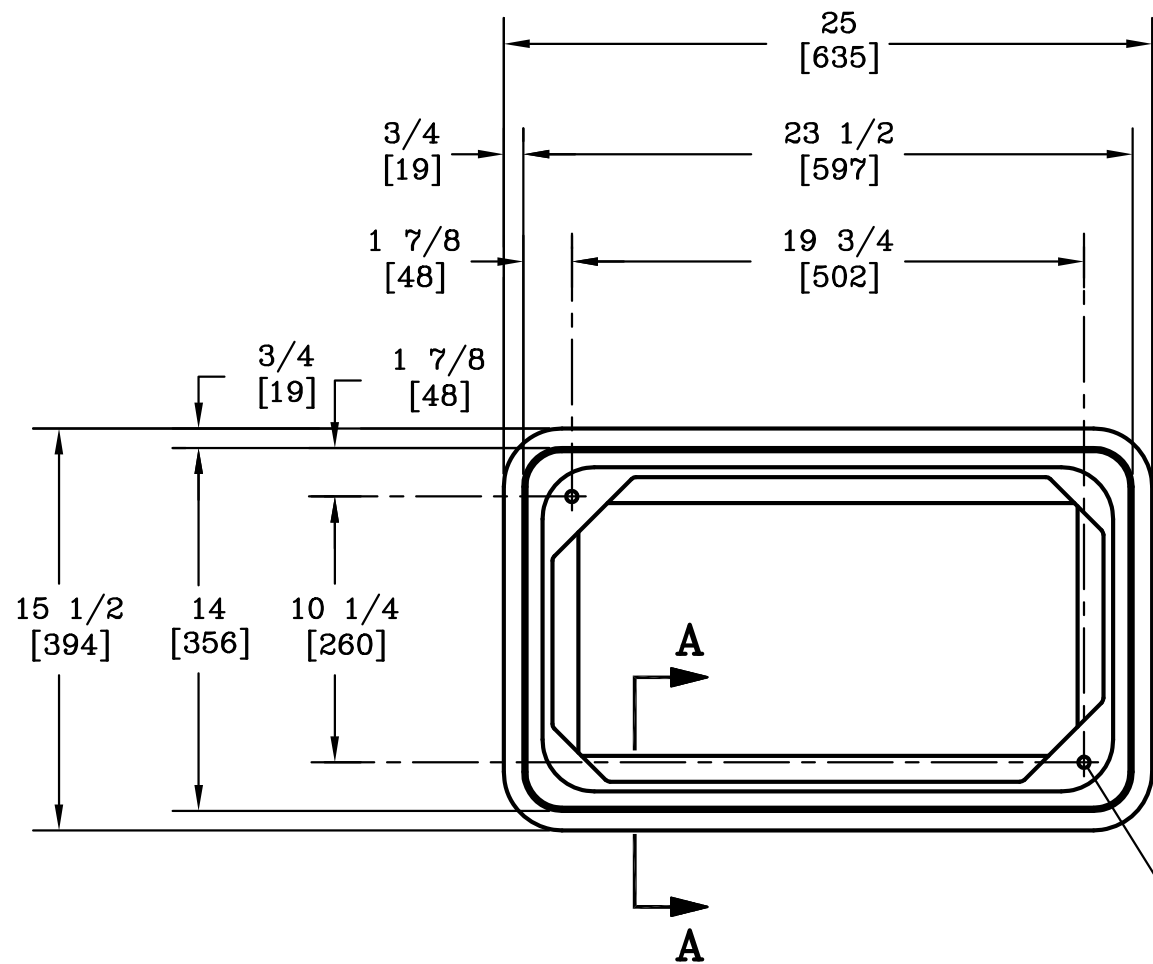

3/8-7 SELF ALIGNING,
REPLACEABLE S.S. EZ-NUT
2 PLACES

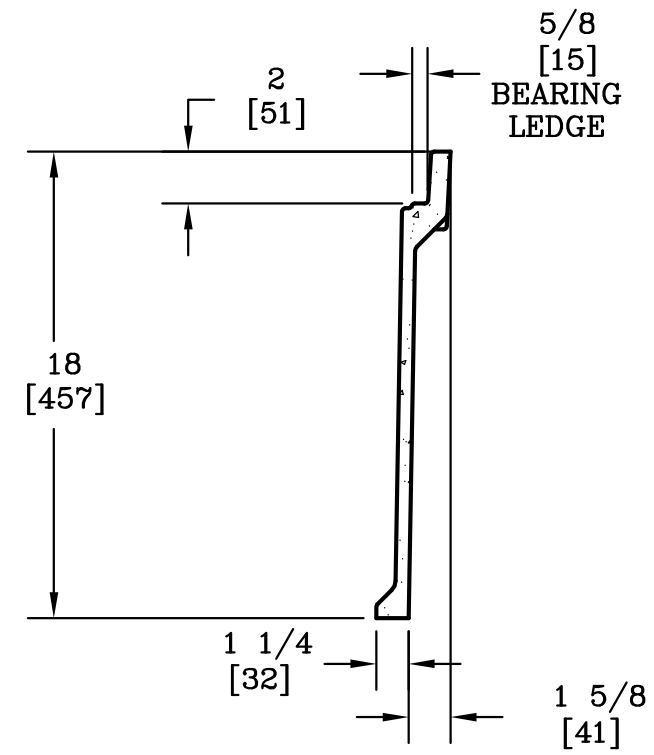

SECTION A-A

NOTE:
1. THIS BOX IS RATED FOR
ANSI/SCTE 77 2010 TIER 22.

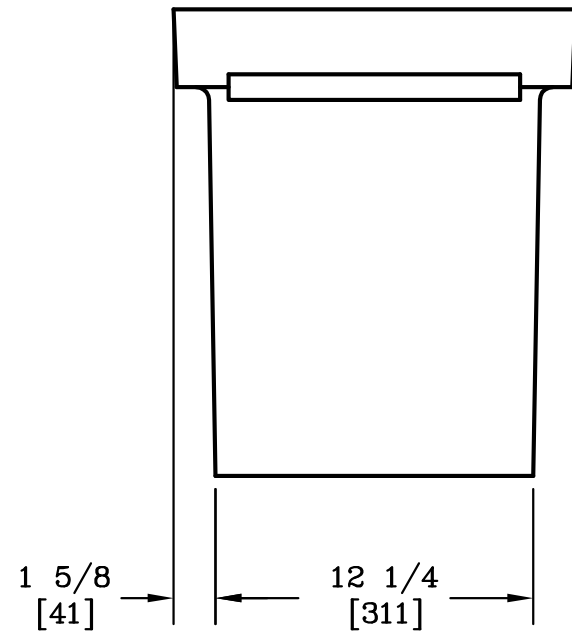
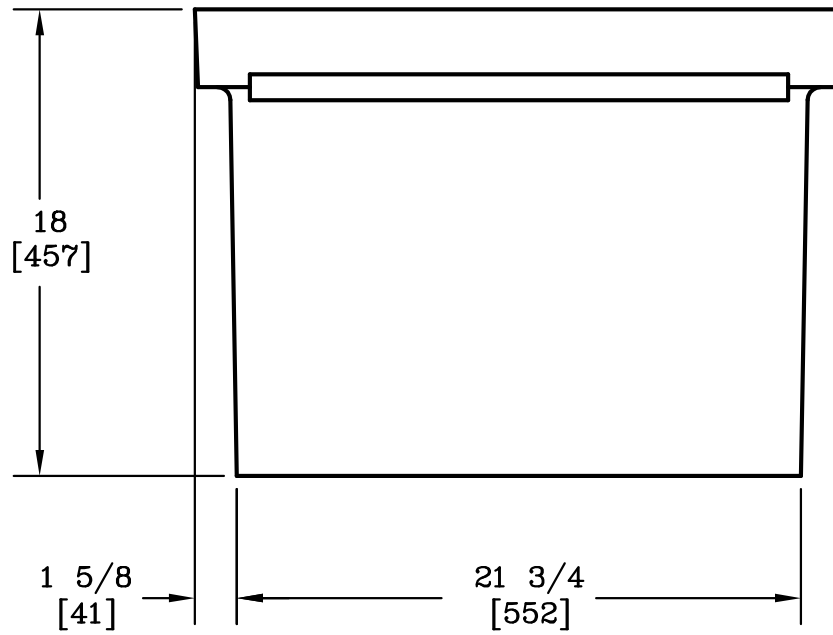

CUSTOMER APPROVAL
APPROVED BY: _____
DATE: _____

DIMENSIONS ARE IN INCHES OR MILLIMETERS IN BRACKETS UNLESS OTHERWISE NOTED.				3621 INDUSTRIAL PARK DR LENOIR CITY, TN 37771 800-346-3062 www.quazite.com	LOC	
DRN	BY	DATE	WEIGHT		DRAWING DESCRIPTION	S
CHK	ENG	APR	APR	73# 33kg.		REV
APR	APR	APR	APR	SCALE	QUAZITE® BOX 13 X 24 X 18	K 3/12
APR	APR	APR	APR	1 1/2"=1'		
PROJECT NUMBER				SIZE	DRAWING NUMBER	
82001				B	PG1324BA18	
SHEET 1 OF 1						